

SPEED - TORQUE CURVE

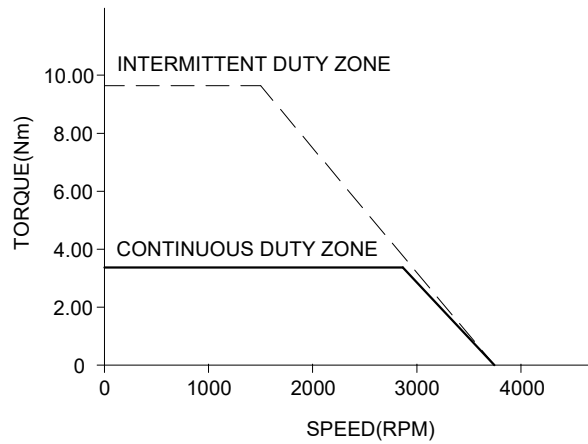

SPECIFICATION	VALUE
RATED POWER(W)	1000
RATED VOLTAGE(VDC)	48
RATED TORQUE(Nm)	3.20
PEAK TORQUE(Nm)	9.60
RATED SPEED(RPM)	3000
RATED CURRENT(Amp)	24.5
BACK EMF CONST(V/KRPM)	8.5±10%
TORQUE CONST(Nm/Amp)	0.13
LINE RESISTANCE(Ω)	0.08±10%
LINE INDUCTANCE(mH)	0.30±20%
INERTIA(Kg ² ·m)	1.92×10 ⁻⁴
INSULATION CLASS	F
IP RATING	IP65
POLES	10
ELECTRICAL TIME CONSTANT(ms)	-
ENCODER RESOLUTION	17 bit
WEIGHT(KG)	2.66

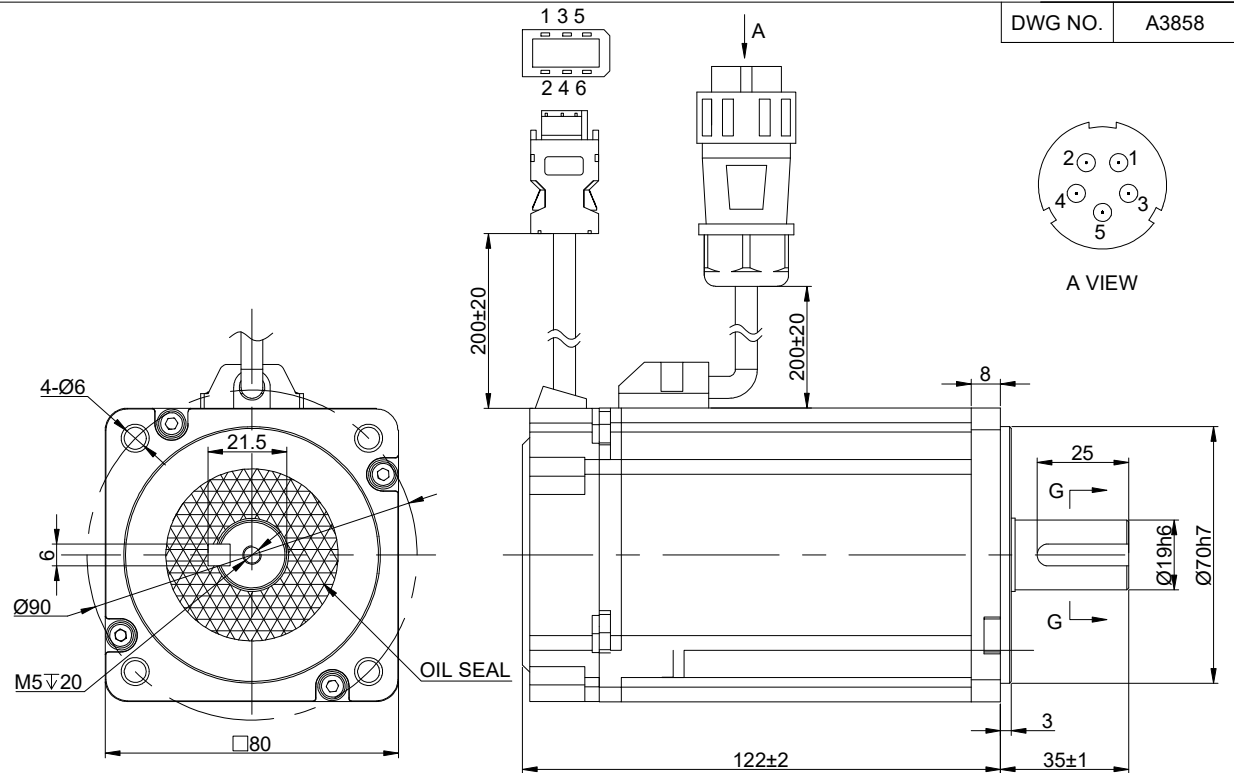

COMMENT:
 1.DYNAMIC AXIAL LOAD: 147N MAX;
 2.DYNAMIC RADIAL LOAD : 392N MAX

SEQUENCE OF MOTOR CABLES					
PIN-NO.	1	2	3	4	5
DESCRIPTION	U	V	W	PE	-
COLOUR	RED	YEL	BLU	YEL/GRN	-

ENCODER CABLE SEQUENCE						
PIN-NO.	1	2	3	4	5	6
DESCRIPTION	+5V	GND	-	-	485+	485-
COLOUR	RED	BLK	-	-	BLU	YEL



	APVD	MYX	12.9.2024
	CHKD		
2:1	DRN	LDJ	11.7.2024
SCALE	SIGNATURE		DATE

DC SERVO MOTOR
 DSY80-1000L2A2M17S